

- I Bruciatori policombustibile gasolio/gas**
- GB Dual fuel Gas-Oil/Gas burners**
- F Brûleurs mixtes fioul/gaz**
- D Mehrstoffbrenner Heizöl/Gas**
- E Quemadores policombustible gasóleo / gas**

Funzionamento bistadio progressivo o modulante lato gas / bistadio lato gasolio
Oil progressive two-stage or modulating operation / Gas two-stage operation
Fonctionnement fioul à deux allures progressives ou modulant / Fonctionnement
gaz à deux allures
Zweistufiger gleitender oder modulierender Betrieb für Öl / Zweistufig für Gas
Funcionamiento a dos llamas progresivas o modulante lado gas / a dos llamas
lado gasóleo

COD.	MOD.	TYP.
3898210	RLS 160/M MX	781 T
3898211	RLS 160/M MX	781 T

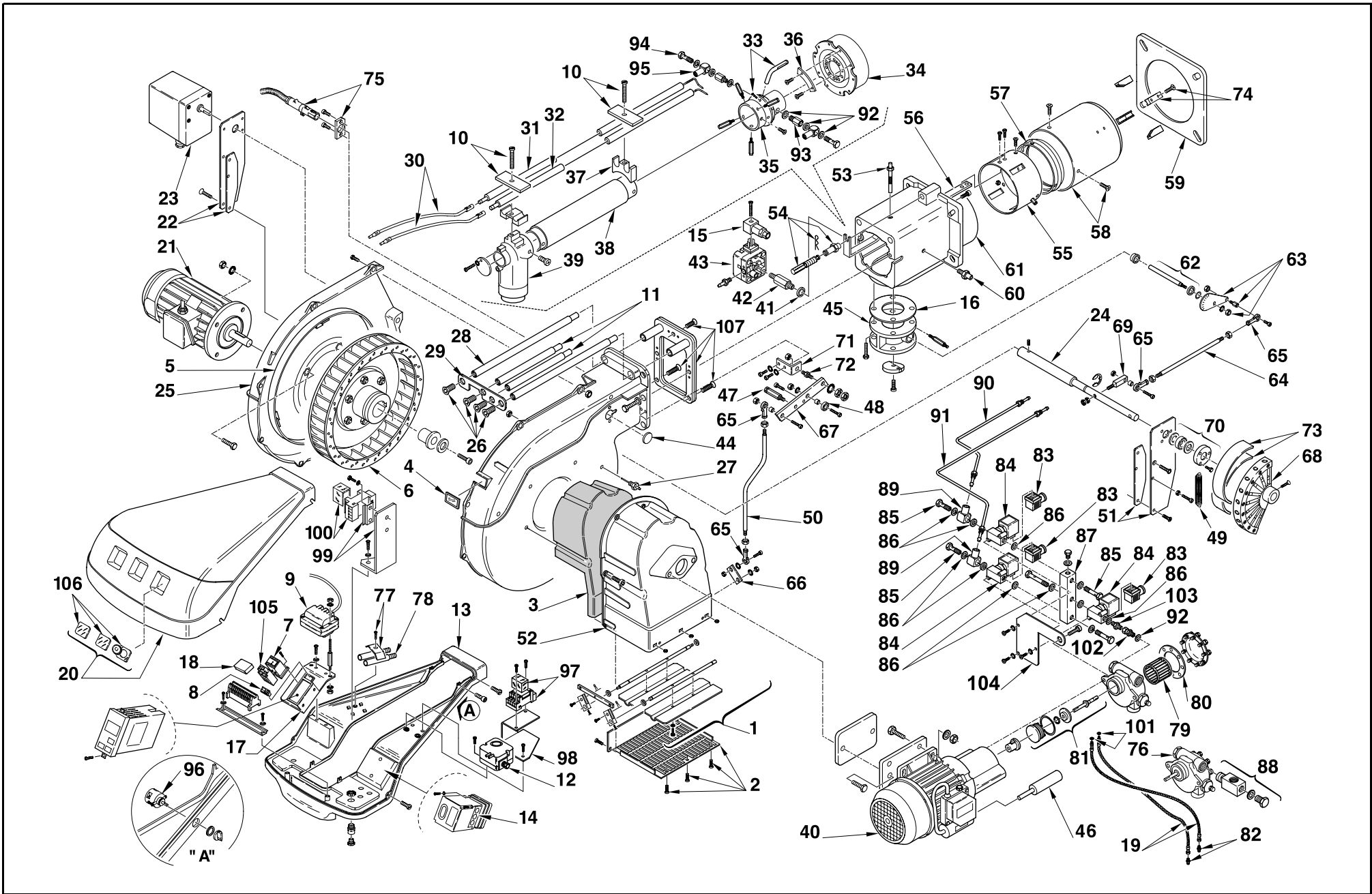

N.	COD.	781 T		DESCRIZIONE	DESCRIPTION	DESCRIPTION	BESCHREIBUNG	DENOMINACION	MATRICOLA BRUCIATORE BURNER SERIAL NUMBER MATRICULE BRULEUR BRENNER KENN-NUMMER MATRICULA QUEMADORES	RICAMBI CONSIGLIATI ADVISED PARTS RECHANGE CONSEIL EMPFOHLENE ERSATZTEILE RECAMBIOS ACONSEJADOS
		3898210	3898211 *							
										**
1	3012583	•	•	GRUPPO SERRANDA	AIR DAMPER ASSEMBLY	GROUPE VOLET AIR	LUFTKLAPPE	CONJUNTO REGISTRO AIRE	≤ 02356XXXXXX	
1	3013684	•	•	GRUPPO SERRANDA	AIR DAMPER ASSEMBLY	GROUPE VOLET AIR	LUFTKLAPPE	CONJUNTO REGISTRO AIRE	≥ 02366XXXXXX	
2	3003086	•	•	PROTEZIONE	GRID	PROTECTION	SCHUTZGITTER	PROTECION	≤ 02356XXXXXX	
2	3013683	•	•	PROTEZIONE	GRID	PROTECTION	SCHUTZGITTER	PROTECION	≥ 02366XXXXXX	
3	3012553	•	•	FONOASSORBENTE	SOUND DAMPING	INSONORISANT	GERÄUSCHDÄMMUNG	AISLAMIENTO ACÚSTICO	≤ 02356XXXXXX	C
3	3013682	•	•	FONOASSORBENTE	SOUND DAMPING	INSONORISANT	GERÄUSCHDÄMMUNG	AISLAMIENTO ACÚSTICO	≥ 02366XXXXXX	C
4	3003763	•	•	VISORE	INSPECTION WINDOW	VEISEUR	SICHTFENSTER	VISOR		
5	3012573	•	•	ANELLO	PISTON SEAL	JOINT TORIQUE	LIPPENDICHTUNG	RACORD		B
6	3012555	•	•	GIRANTE	FAN	TURBINE	GEBLÄSERAD	TURBINA		C
7	3003637	•	•	CONTATTORE	CONTACTOR	CONTACTEUR	SCHÜTZ	CONTACTOR		C
8	3012080	•	•	INTERRUTTORE	SWITCH	INTERRUPTEUR	SCHALTER	INTERRUPTOR		C
9	3003785	•	•	TRASFORMATORE	TRANSFORMER	TRANSFORMATEUR	ZÜNDTRANSFORMATOR	TRANSFORMADOR		B
10	3012626	•	•	PIASTRINA	PLATE	PLAQUETTE ETRIER	PLATTE	PLATTE		
11	3012627	•	•	PROLUNGA PERNO	BAR EXTENSION	RALLONGE DE GLISSIERE	VERLÄNGERUNG	PROLUNGACIÓN PERNO	≤ 02356XXXXXX	
11	3013686	•	•	PROLUNGA PERNO	BAR EXTENSION	RALLONGE DE GLISSIERE	VERLÄNGERUNG	PROLUNGACIÓN PERNO	≥ 02366XXXXXX	
12	3007444	•	•	PRESSOSTATO ARIA	AIR PRESSURE SWITCH	PRESSOSTAT AIR	LUFTDRUCKWÄCHTER	PRESÓSTATO AIRE		A
13	3013171	•	•	MENSOLA	BASE PLATE	PLAQUE DE SUPPORT	GRUNDPLATTE	REPISA		
14	3006090	•	•	APPARECCHIATURA	CONTROL BOX	BOITE DE CONTROLE	STEUERGERÄT	CAJA CONTROL		B
15	3012347	•	•	PRESA	SOCKET	PRISE	STECKBUCHSE	CONECTOR		C
16	3005482	•	•	GUARNIZIONE	SEAL	RONDELLE	FLANSCHDICHTUNG	JUNTA		B
17	3012343	•	•	SUPPORTO	SUPPORT	SUPPORT	HALTER	SOPORTE		
18	3012155	•	•	FILTRO ANTIDISTURBO	DEGLITCHER	FILTRE	ENTSTÖRER	FILTRO ANTI-INTERFERENCIA		C
19	3006182	•	•	TUBO FLESSIBILE	FLEXIBLE OIL LINE	FLEXIBLE	SCHLAUCH	TUBO FLEXIBLE		
20	3013119	•	•	COFANO	COVER	COFFRET	VERKLEIDUNG	ENVOLVENTE		
21	3012557	•	•	MOTORE	MOTOR	MOTEUR	MOTOR	MOTOR		C
22	3012585	•	•	PIASTRA	ANCHOR PLATE	PLATINE DE BLOCAGE	ARRETIERPLATTE	PLACA		
23	3012345	•	•	SERVOMOTORE	SERVOMOTOR	SERVOMOTEUR	STELLMOTOR	SERVOMOTOR		
24	3012349	•	•	ALBERO	SHAFT	ARBRE	WELLE	ARBORILLO		
25	3012587	•	•	GUSCIO	HALF-SHELL	COUVERCLE	HAUBE	CÀSCARA		
26	3003481	•	•	VITE	SCREW	VIS	SCHRAUBE	TORNILLO	≤ 02356XXXXXX	
26	3013681	•	•	VITE	SCREW	VIS	SCHRAUBE	TORNILLO	≥ 02366XXXXXX	
27	3003891	•	•	RACCORDO	CONNECTOR	MAMELON	NIPPEL	RACORD		C
28	3012628	•	•	PERNO	BAR	GLISSIERE	BOLZEN	PERNO	≤ 02356XXXXXX	C
29	3012629	•	•	STAFFA	BRACKET	SUPPORT	KONSOLE	SOPORTE	≤ 02356XXXXXX	
30	3003795	•	•	COLLEGAMENTO ELETTRODO	H.T. LEAD	CONNEXION POUR ELECTRODE	VERBINDUNG FÜR ELEKTRODE	CABLE CONEXIÓN		
31	3013172	•		ELETTRODO	ELECTRODE	ELECTRODE PORCELAINE	ELEKTRODE	ELECTRODO		A
31	3013173	•		ELETTRODO	ELECTRODE	ELECTRODE PORCELAINE	ELEKTRODE	ELECTRODO		A
32	3013174	•		ELETTRODO	ELECTRODE	ELECTRODE PORCELAINE	ELEKTRODE	ELECTRODO		A
32	3013175	•		ELETTRODO	ELECTRODE	ELECTRODE PORCELAINE	ELEKTRODE	ELECTRODO		A
33	3013181	•	•	TUBETTO	TUBE	TUYAU	RÖHRCHEN	TUBO		
34	3013176	•	•	TAZZA	AIR DIFFUSER	DIFFUSEUR D'AIR	FLAMMKOPFBECHE	DIFUSOR DEL AIRE		A
35	3013177	•	•	DISTRIBUTORE	GAS HEAD	DISTRIBUTEUR	GASVERTEILER	DISTRIBUIDOR		
36	3013178	•	•	PARZIALIZZATORE	SHUTTER	CLAPET	STAUSCHEIBE	ELICEPARIALIZADORA		
37	3013179	•	•	SUPPORTO	SUPPORT	SUPPORT	HALTER	SOPORTE		

N.	COD.	781 T		DESCRIZIONE	DESCRIPTION	DESCRIPTION	BESCHREIBUNG	DENOMINACION	MATRICOLA BRUCIATORE BURNER SERIAL NUMBER MATICULE BRULEUR BRENNER KENN-NUMMER MATRICULA QUEMADORES	RICAMBI CONSIGLIATI ADVISED PARTS RECHANGE CONSEIL EMPFOHLENE ERSATZTEILE RECAMBIOS ACONSEJADOS
		3898210	3898211 *							
38	3012636	•	•	TUBO ESTERNO	EXTERIOR TUBE	TUYAU EXTERIEUR	AUSSERER ROHR	TUBO EXTERNO		
38	3012920	•	•	TUBO ESTERNO	EXTERIOR TUBE	TUYAU EXTERIEUR	AUSSERER ROHR	TUBO EXTERNO		
39	3012637	•	•	GOMITO	ELBOW	COUDE	SCHLITTEN	CODO		
40	3013180	•	•	MOTORE	MOTOR	MOTEUR	MOTOR	MOTOR	≤ 02436999999	C
40	3013829	•	•	MOTORE	MOTOR	MOTEUR	MOTOR	MOTOR	≥ 02446000000	C
41	3007088	•	•	GUARNIZIONE	SEAL	RONDELLE	METALLDICHTUNG	JUNTA		C
42	3006615	•	•	RACCORDO	CONNECTOR	MAMELON	NIPPEL	RACORD		C
43	3003660	•	•	PRESSOSTATO GAS	GAS PRESSURE SWITCH	PRESSOSTAT GAZ	GAS DRUCKWÄCHTER	PRESÓSTATO GAS		B
44	3003996	•	•	TAPPO	PLUG	BOUCHON A VIS	SCHRAUBSTÖPSEL	TAPÓN		
45	3006096	•	•	REGOLATORE GAS	GAS REGULATOR	REGULATEUR GAZ	GAS REGLER	REGULACION GAS		C
46	3013182	•	•	CONDENSATORE	CONDENSER	CONDENSATEUR	KONDENSATOR	CONDENSADOR	≤ 02436999999	B
46	3013875	•	•	CONDENSATORE	CONDENSER	CONDENSATEUR	KONDENSATOR	CONDENSADOR	≥ 02446000000	B
47	3012352	•	•	PERNO	BAR	GLISSIERE	BOLZEN	PERNO		C
48	3003841	•	•	CUSCINETTO	BEARING	ROULEMENT	LAGER	COJINETE		
49	3012356	•	•	MOLLA	SPRING	RESSORT	FEDER	MUELLE		C
50	3012646	•	•	TIRANTE	TIE ROD	TIRANT	GESTÄNGE	TIRANTE		C
51	3012594	•	•	PIASTRA	ANCHOR PLATE	PLATINE DE BLOCAGE	ARRETIERPLATTE	PLACA		
52	3012828	•	•	BOCCA D'ASPIRAZIONE	AIR INTAKE	BOITIER D'ASPIRATION	ANSAUGÖFFNUNG	BOCA DE ASPIRACIÓN	≤ 02356XXXXXX	
53	3012049	•	•	VITE	SCREW	VIS	SCHRAUBE	TORNILLO		
54	3012639	•	•	GRUPPO REGOLATORE	CONTROL DEVICE	GROUPE OBTURATION	DRUCKREGULIERUNG	GRUPO REGULACION		C
55	3012640	•	•	CILINDRO	SLEEVE	CYLINDRE	ZYLINDER	CILINDRO		C
56	3012641	•	•	STAFFA	BRACKET	SUPPORT	KONSOLE	SOPORTE		
56	3012922	•	•	STAFFA	BRACKET	SUPPORT	KONSOLE	SOPORTE		
57	3012642	•	•	OTTURATORE	SHUTTER	OBTURATEUR	SCHIEBER	OBTURADOR		C
58	3012643	•	•	IMBUTO FIAMMA	END CONE	EMBOUT GUEULARD	FLAMMENROHR	TUBO EXTREMO		B
58	3012923	•	•	IMBUTO FIAMMA	END CONE	EMBOUT GUEULARD	FLAMMENROHR	TUBO EXTREMO		B
59	3012562	•	•	SCHERMO	FLANGE GASKET	ECRAN THERMIQUE	FLASCHDICHTUNG	JUNTA AISLANTE		A
60	3003322	•	•	RACCORDO	CONNECTOR	MAMELON	NIPPEL	RACORD		C
61	3013184	•	•	MANICOTTO	MANIFOLD	MANCHON	GASANSCHLUSS	COLARIN	≤ 02356XXXXXX	
62	3006132	•	•	ALBERO E ANELLO	SHAFT AND RING	ARBRE ET ANNEAU	WELLE UND RING	ÁRBOLILLO Y ANILLO		C
63	3012644	•	•	QUADRANTE	GRADUATE SECTOR	SECTEUR GRADUE	SKALENSEGMENT	SECTOR GRADUADO		
64	3012600	•	•	TIRANTE	TIE ROD	TIRANT	GESTÄNGE	TIRANTE	≤ 02356XXXXXX	
64	3003543	•	•	TIRANTE	TIE ROD	TIRANT	GESTÄNGE	TIRANTE	≥ 02366XXXXXX	
65	3006098	•	•	SNODO SFERICO	PIN JOINT	CHAPE A ROTULE	KUGELGELENK	ARTICOLACION ESFERICA		C
66	3012601	•	•	LEVA	LEVER	LEVIER	HEBEL	PALANCA		C
67	3012354	•	•	LEVA	LEVER	LEVIER	HEBEL	PALANCA		C
68	3012358	•	•	CAMMA	CAM	CAME	NOCKEN	EXCÉNTRICO		C
69	3012350	•	•	LEVA	LEVER	LEVIER	HEBEL	PALANCA		C
70	3012357	•	•	CUSCINETTO	BEARING	ROULEMENT	LAGER	COJINETE		
71	3012602	•	•	SUPPORTO	SUPPORT	SUPPORT	HALTER	SOPORTE		
72	3012603	•	•	PERNO	BAR	GLISSIERE	BOLZEN	PERNO		C
73	3006097	•	•	MOLLA	SPRING	RESSORT	FEDER	MUELLE		C
74	3012647	•	•	BASSETTA	CENTERING SUPPORT	ELEMENT DE CENTRAGE	ZENTRIERHALTERUNG	SOPORTE		
75	3003396	•	•	FOTOCCELLULA U.V.	DETECTOR	PHOTOCELLULE U.V.	U.V. PHOTOZELLE	FOTORESISTENCIA		A
76	3006369	•	•	POMPA	PUMP	POMPE	PUMPE	BOMBA		C

* = Versione Testa Lunga - Long Combustion Head Version - Version Tête Longue - Langer Brennkopf Ausführung - Versión alargado de tubo llama

N.	COD.	781 T		DESCRIZIONE	DESCRIPTION	DESCRIPTION	BESCHREIBUNG	DENOMINACION	MATRICOLA BRUCIATORE BURNER SERIAL NUMBER MATRICULE BRULEUR BRENNER KENN-NUMMER MATRICULA QUEMADORES	RICAMBI CONSIGLIATI ADVISED PARTS RECHANGE CONSEIL EMPFOHLENE ERSATZTEILE RECAMBIOS ACONSEJADOS
		3898210	3898211 *							
										**
77	3003409	•	•	CAVALLOTTO	U BOLT	CAVALIER	BÜGELBOLZEN	FIJACION ELECTRODO	≤ 02356XXXXXX	
78	3003956	•	•	PROLUNGA PERNO	BAR EXTENSION	RALLONGE DE GLISSIERE	VERLÄNGERUNG	PROLUNGACIÓN PERNO	≤ 02356XXXXXX	
78	3013687	•	•	PROLUNGA PERNO	BAR EXTENSION	RALLONGE DE GLISSIERE	VERLÄNGERUNG	PROLUNGACIÓN PERNO	≥ 02366XXXXXX	
79	3006787	•	•	FILTRO	FILTER	FILTRE	FILTER	FILTRO		A
80	3006292	•	•	GUARNIZIONE	SEAL	RONDELLE	METALLDICHTUNG	JUNTA		B
81	3000805	•	•	ORGANO DI TENUTA	PUMP SEAL	ORGANE D'ETANCHEITE	WELLENDICHTUNG	CONJUNTO ESTANQUIDAD		B
82	3006181	•	•	RACCORDO	CONNECTOR	MAMELON	NIPPEL	RACORD		C
83	3006953	•	•	PRESA	HOLDER	PRISE CELLULE	SOCKEL	CONECTOR		B
84	3012002	•	•	VALVOLA	NEEDLEVALVE	VANNE POINTEAU	NADELVENTIL	VÁLVULA		
85	3003592	•	•	PERNO	BAR	GLISSIERE	BOLZEN	PERNO		C
86	3007077	•	•	GUARNIZIONE	SEAL	RONDELLE	METALLDICHTUNG	JUNTA		B
87	3012569	•	•	COLLETTORE	MANIFOLD	COLLECTEUR	SAMMLER	COLECTOR		C
88	3003681	•	•	RACCORDO	CONNECTOR	MAMELON	NIPPEL	RACORD		C
89	3006722	•	•	RACCORDO	CONNECTOR	MAMELON	NIPPEL	RACORD		C
90	3013186	•	•	TUBO	TUBE	TUYAUTERIE	DRUCKROHR	TUBO	≤ 02126999999	
90	3013666	•	•	TUBO	TUBE	TUYAUTERIE	DRUCKROHR	TUBO	≥ 02136000001; ≤ 02356XXXXXX	
90	3013688	•	•	TUBO	TUBE	TUYAUTERIE	DRUCKROHR	TUBO	≥ 02366XXXXXX	
90	3013191	•	•	TUBO	TUBE	TUYAUTERIE	DRUCKROHR	TUBO	≤ 02126999999	
90	3013667	•	•	TUBO	TUBE	TUYAUTERIE	DRUCKROHR	TUBO	≥ 02136000001; ≤ 02356XXXXXX	
90	3013689	•	•	TUBO	TUBE	TUYAUTERIE	DRUCKROHR	TUBO	≥ 02366XXXXXX	
91	3013187	•	•	TUBO	TUBE	TUYAUTERIE	DRUCKROHR	TUBO	≤ 02126999999	
91	3013668	•	•	TUBO	TUBE	TUYAUTERIE	DRUCKROHR	TUBO	≥ 02136000001; ≤ 02356XXXXXX	
91	3013690	•	•	TUBO	TUBE	TUYAUTERIE	DRUCKROHR	TUBO	≥ 02366XXXXXX	
91	3013192	•	•	TUBO	TUBE	TUYAUTERIE	DRUCKROHR	TUBO	≤ 02126999999	
91	3013669	•	•	TUBO	TUBE	TUYAUTERIE	DRUCKROHR	TUBO	≥ 02136000001; ≤ 02356XXXXXX	
91	3013691	•	•	TUBO	TUBE	TUYAUTERIE	DRUCKROHR	TUBO	≥ 02366XXXXXX	
92	3007079	•	•	GUARNIZIONE	SEAL	RONDELLE	METALLDICHTUNG	JUNTA		B
93	3013188	•	•	RACCORDO	CONNECTOR	MAMELON	NIPPEL	RACORD		C
94	3003006	•	•	PERNO	BAR	GLISSIERE	BOLZEN	PERNO		C
95	3006784	•	•	RACCORDO	CONNECTOR	MAMELON	NIPPEL	RACORD		C
96	3012310	•	•	COMMUTATORE	SELECTOR SWITCH	COMMUTATOR	WAHLSCHALTER	CONMUTADOR		
97	3012292	•	•	RELE' TERMICO	OVERLOAD	RELAIS THERMIQUE	ÜBERSTROMAUSLÖSER	RELÉ TÉRMICO		C
98	3012423	•	•	SUPPORTO	BRACKET	SUPPORT	HALTERUNG	SOPORTE		
99	3013189	•	•	SUPPORTO	BRACKET	SUPPORT	HALTERUNG	SOPORTE		
100	3013190	•	•	RELE' TERMICO	OVERLOAD	RELAIS THERMIQUE	ÜBERSTROMAUSLÖSER	RELÉ TÉRMICO		C
101	3007164	•	•	GUARNIZIONE	SEAL	RONDELLE	METALLDICHTUNG	JUNTA	≥ 02136000001	B
102	3013462	•	•	RACCORDO GIREVOLE	SWIVEL FITTING	TOURNANT	DREHANSCHLUSS	EMPALME GIRATORIO	≥ 02136000001	C

N.	COD.	781 T		DESCRIZIONE	DESCRIPTION	DESCRIPTION	BESCHREIBUNG	DENOMINACION	MATRICOLA BRUCIATORE BURNER SERIAL NUMBER MATRICULE BRULEUR BRENNER KENN-NUMMER MATRICULA QUEMADORES	RICAMBI CONSIGLIATI ADVISED PARTS RECHANGE CONSEIL EMPFOHLENE ERSATZTEILE RECAMBIOS ACONSEJADOS
		3898220	3898221 *							
103	3013185	•	•	RACCORDO	CONNECTOR	MAMELON	NIPPEL	RACORD	≥ 02136000001	C
104	3013671	•	•	STAFFA	BRACKET	SUPPORT	KONSOLE	SOPORTE		
105	3013676	•	•	RELÈ TERMICO	OVERLOAD	RELAIS THERMIQUE	ÜBERSTROMAUSLÖSER	RELÈ TERMICO		C
106	3013678	•	•	MEMBRANA+VETRINO	MEMBRANE+VIEWING PORT	MEMBRANE+REGARD	MEMBRAN+VERSCHLUßSTOPFEN	MEMBRANA+MIRILLA		
107	3013685	•	•	GRUPPO PIASTRE	PLATES ASSEMBLY	GROUPE PLATINES	PLATTENGRUPPE	CONJUNTO PLACAS	≥ 02366XXXXXX	

* = Versione Testa Lunga - Long Combustion Head Version - Version Tête Longue - Langer Brennkopf Ausführung - Versión alargado de tubo llama

**

A = Ricambi per dotazione minima - Spare parts for minimum fittings - Pièces détachées pour équipement minimum - Ersatzteile für minimale Ausstattung - Recambios para equipamiento mínimo

A+B = Ricambi per dotazione base di sicurezza - Spare parts for basic safety fittings - Pièces détachées pour équipement standard de sécurité - Ersatzteile für Sicherheitsgrundausrüstung - Recambios para equipamiento básico de seguridad

A+B+C = Ricambi per dotazione estesa di sicurezza - Spare parts for extended safety fittings - Pièces détachées pour équipement complet de sécurité - Ersatzteile für erweiterte Sicherheitsausstattung - Recambios para equipamiento general de seguridad



RIELLO S.p.A.
I - 37048 Legnago (VR)
Tel. +39.0442.630111
[http:// www.rielloburners.com](http://www.rielloburners.com)